



Universal Switch (Single Pole or 3 Way)

Rated: 10A-120VAC, 60HZ

Cat. No. HCS10

Incandescent: 1200W max.,
10A-120VAC

Fluorescent: 1200VA max.,
10A-120VAC

Magnetic Low-Voltage: 1200VA max.,
10A-120VAC

Supplemental: 1/4hp – 5.8A, 120VAC

INSTALLATION INSTRUCTIONS



DI-000-HCS10-00B

LIMITED 2 YEAR WARRANTY AND EXCLUSIONS

Leviton warrants to the original consumer purchaser and not for the benefit of anyone else that this product at the time of its sale by Leviton is free of defects in materials and workmanship under normal and proper use for two years from the purchase date. Leviton's only obligation is to correct such defects by repair or replacement, at its option, if within such two year period the product is returned prepaid, with proof of purchase date, and a description of the problem to **Leviton Manufacturing Co., Inc., Attn: Quality Assurance Department, 59-25 Little Neck Parkway, Little Neck, New York 11362-2591**. This warranty excludes and there is disclaimed liability for labor for removal of this product or reinstallation. This warranty is void if this product is installed improperly or in an improper environment, overloaded, misused, opened, abused, or altered in any manner, or is not used under normal operating conditions or not in accordance with any labels or instructions. There are no other or implied warranties of any kind, including merchantability and fitness for a particular purpose, but if any implied warranty is required by the applicable jurisdiction, the duration of any such implied warranty, including merchantability and fitness for a particular purpose, is limited to two years. Leviton is not liable for incidental, indirect, special, or consequential damages, including without limitation, damage to, or loss of use of, any equipment, lost sales or profits or delay or failure to perform this warranty obligation. The remedies provided herein are the exclusive remedies under this warranty, whether based on contract, tort or otherwise.

For Technical Assistance Call:
1-800-824-3005 (U.S.A. Only)
www.leviton.com



DI-000-HCS10-00B

FEATURES

- Leviton's Decora® Style design
- Intellisense Circuitry
- Works with Transmitters and Controllers
- ON/OFF LED indicates status of load
- DHC Scene Capable
- One Button Programming
- Color conversion available

INTRODUCTION

Leviton Residential Powerline Carrier Components are designed to provide the greatest signal integrity and noise immunity possible. However, in some environments intense electrical noise can cause interference with the signal. Leviton has developed hardware and techniques for overcoming this interference when properly applied.

LEVITON'S DHC DEVICES FEATURE INTELLISENSE, THE RIGHT TYPE OF AUTOMATIC GAIN CONTROL (AGC)

Leviton DHC devices use Intellisense, a special gated-type of AGC, to help eliminate noise problems. This circuit feature is ideal for powerline carrier systems because it only operates during the signal window when receivers listen for command signals. Noise levels in the signal window are never as high as they are during other portions of the AC power curve. Therefore, Leviton's Intellisense gated AGC will desensitize a receiver to noise signals with only a minimal reduction in command signal sensitivity. The result: Problems from noise interference are dramatically reduced without affecting overall system performance.

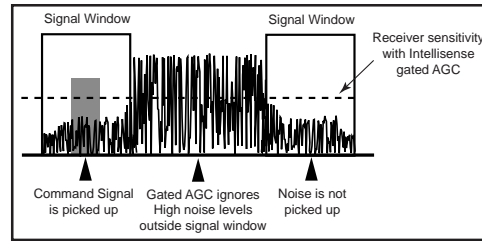

It is the responsibility of the specifier/installer to test for signal strength and the presence of noise using Leviton test equipment, Cat. Nos. 6385 (Signal Test Transmitter) and 6386 (Signal Strength Indicator), and to properly apply signal coupling and noise reduction equipment according to the guidelines provided in the Decora Home Controls (DHC) Technical Manual and the DHC Troubleshooting Guide.

Leviton specifically denies any warranty of performance, stated or implied, where electrical noise interference exists at the time of installation, or subsequent to installation by the addition of noise-producing devices or equipment, or where these components have been installed for non-residential applications.

DHC Components are for residential use only. Installation for any other application voids any warranty, stated or implied.

DESCRIPTION

The Leviton Universal Switch, Cat. No. HCS10, is designed for use with DHC Residential Powerline Carrier Components. Cat. No. HCS10 functions as a remote switching device which responds to coded ON/OFF, and ALL LIGHTS ON/OFF commands.

Cat. No. HCS10 can be operated manually as a standard type switch. The module may be set to any of 256 address codes, to be selected at the time of installation. The desired address is set by depressing and holding the recessed button until the ON/OFF LED flashes. The code is then learned from any transmitter when it sends the DHC command. The module is equipped with six-inch leads and installs in a standard wall box. It is suitable for incandescent, fluorescent and magnetic low-voltage lighting loads.

FCC COMPLIANCE STATEMENT

This equipment has been tested and found to comply with the limits for a Class B Digital Device, pursuant to Part 15 of the FCC Rules. These limits are designed to provide reasonable protection against harmful interference in a residential installation. This equipment generates, uses, and can radiate radio frequency energy and, if not installed and used in accordance with the instructions, may cause harmful interference to radio communications. However, there is no guarantee that interference will not occur in a particular installation. If this equipment does cause harmful interference to radio or television reception, which can be determined by turning the equipment OFF an ON, the user is encouraged to try to correct the interference by one or more of the following measures:

- Reorient or relocate the receiving Antenna.
- Increase the separation between the equipment and the receiver.
- Connect the equipment into an outlet on a circuit different from that to which the receiver is connected.
- Consult the dealer or an experienced radio/tv technician for help.

INSTALLATION INSTRUCTIONS

WARNING: TO BE INSTALLED AND/OR USED IN ACCORDANCE WITH APPROPRIATE ELECTRICAL CODES AND REGULATIONS.

WARNING: IF YOU ARE NOT SURE ABOUT ANY PART OF THESE INSTRUCTIONS, CONSULT A QUALIFIED ELECTRICIAN.

WARNING: TO REDUCE THE RISK OF OVERHEATING AND POSSIBLE DAMAGE TO OTHER EQUIPMENT, DO NOT INSTALL TO CONTROL A RECEPTACLE, MOTOR-OPERATED APPLIANCE, OR A TRANSFORMER-SUPPLIED APPLIANCE, OTHER THAN THE APPROPRIATE LOW-VOLTAGE LIGHTING.

CAUTION (For Incandescent Only): USE WITH INCANDESCENT OR 120V HALOGEN FIXTURES ONLY.

CAUTION (For Magnetic Low-Voltage Only):

1. USE WITH MAGNETIC LOW-VOLTAGE TRANSFORMERS, INCANDESCENT, OR 120V MAGNETIC LOW-VOLTAGE HALOGEN FIXTURES ONLY. USE A LEVITON ELECTRONIC LOW-VOLTAGE DIMMER TO CONTROL ELECTRONIC (SOLID STATE) LOW-VOLTAGE TRANSFORMERS.
2. WHEN A MAGNETIC LOW-VOLTAGE CIRCUIT IS OPERATED AT A DIM LEVEL, WITH ALL LAMPS INOPERATIVE, EXCESS CURRENT MAY FLOW THROUGH THE TRANSFORMER. TO AVOID POSSIBLE TRANSFORMER FAILURE DUE TO OVERCURRENT, USE A TRANSFORMER THAT INCORPORATES THERMAL PROTECTION OR A FUSE AT THE PRIMARY WINDINGS..

OTHER CAUTIONS AND NOTES:

1. DISCONNECT POWER WHEN SERVICING FIXTURE OR CHANGING BULBS.
2. USE THIS DEVICE ONLY WITH COPPER OR COPPER CLAD WIRE. WITH ALUMINUM WIRE USE ONLY DEVICES MARKED CO/ALR OR CU/AL.
3. SAVE THIS INSTRUCTION SHEET. IT CONTAINS IMPORTANT TECHNICAL DATA ALONG WITH TESTING AND TROUBLESHOOTING INFORMATION WHICH WILL BE USEFUL AFTER INSTALLATION IS COMPLETE.

TO INSTALL:

1. **WARNING:** TO AVOID FIRE, SHOCK, OR DEATH; **TURN OFF POWER** AT CIRCUIT BREAKER OR FUSE AND TEST THAT POWER IS OFF BEFORE WIRING!
2. Remove existing wallplate and switch or dimmer, if applicable.
3. Remove 3/4" (1.9 cm) of insulation from each circuit conductor. Make sure that ends of conductors are straight.
4. Connect lead wires per appropriate WIRING DIAGRAM as follows: Twist strands of each lead tightly and, with circuit conductors, push firmly into appropriate wire connector. Screw connectors on clockwise making sure that no bare conductor shows below the wire connectors. Secure each connector with electrical tape.

NOTE: For single pole applications, cap YELLOW lead with an appropriate size wire connector. Secure connector with electrical tape.

5. Mount device "TOP" up to wall box with screws provided. Restore power at circuit breaker or fuse.
6. Using a small pointed object (i.e., small screwdriver), depress and hold the Program Switch until the ON/OFF LED flashes (refer to Figure 2). The unit is now ready to accept a DHC code.

At a DHC single controller, verify code setting to be learned and press upper rocker. The switch will now accept and memorize code. (refer to Figure 2).

On a multi-button transmitter, verify base code then press the appropriate ON button of row desired. The switch will accept and memorize the appropriate code for that button.

NOTE: The code can be changed by repeating the procedure and selecting a different code or button.

7. If it is desirable to change the color of the device, do so now by following the "Color Conversion Procedure".
8. Remount switch plate if applicable, ensuring that the tabs with cutouts in strap are aligned with cutouts in frame.
9. Attach wallplate. **INSTALLATION IS COMPLETE.**

Figure 1 – Switch Plate Removal

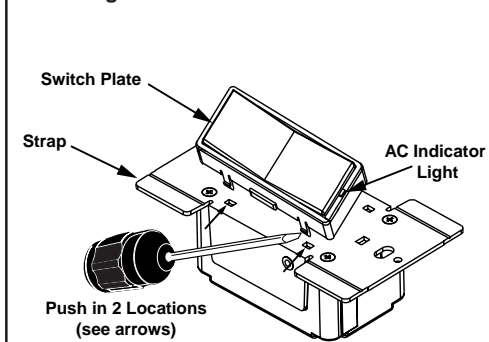
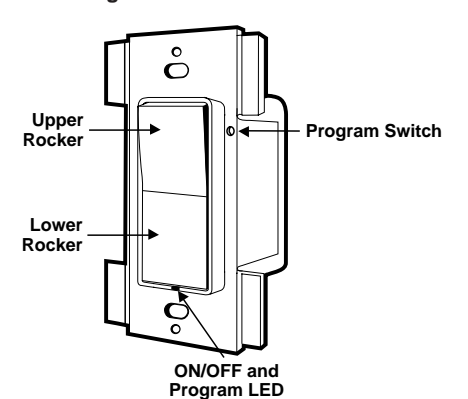

Figure 2 – Switch Functions



COLOR CONVERSION PROCEDURE

The color of Cat. No. HCS10 can be changed to suit your interior design requirements. Simply obtain a color conversion kit of the appropriate color from your Leviton distributor or use the one provided, and proceed as follows:

1. The switch plate has snaps on its sides. Place the tip of a small-bladed screwdriver under a snap and gently pry off the switch plate (**refer to Figure 1**).
2. Take the new switch plate and position it properly to the strap. Notice that the switch plate has an A/C indicator light at one end. The switch plate should be installed with the A/C indicator light positioned at the bottom. With the switch plate properly positioned, gently press it into place until it seats properly with a click. **The color conversion is complete.**

TO OPERATE

ON: Tap the upper half of the rocker. The lights will turn ON.

OFF: Tap the lower half of the rocker. The lights will turn OFF.

NOTE:

To alert you that there is power to the switch when the load is OFF, the AC Indicator Light remains ON. To alert you that the load is ON, the AC Indicator Light remains OFF.

NOTE: If a power interruption should occur while the device is on, the light load will return to its ON state when power is restored.

TESTING PROCEDURE

With Cat. No. HCS10 properly wired and powered-up, tap the switch plate several times to ensure that the switch is turning its load ON and OFF in response to manual control. Leave the switch in the ON position. Next, use a Cat. No. 6320, Leviton Table Top Controller, or any other controller, to check for proper switch operation as follows:

1. Transmit an OFF command to the switch. It should respond by turning its assigned Load OFF.
2. Transmit an ALL LIGHTS ON command to this switch from an appropriately coded controller. It should respond by turning its assigned Load ON.
3. Transmit an ALL OFF command from an appropriately coded controller. It should respond by turning its assigned Load OFF.

PERFECT PERFORMANCE CHECKLIST

If the Cat. No. HCS10 appears to be functioning improperly proceed with the following steps:

1. Confirm that the HCS10 is wired exactly as shown in the WIRING DIAGRAM.
2. Confirm that the switch is being supplied from a 120V, 60Hz AC source ONLY.
3. Confirm that the load being controlled is in proper working order. Local switch, ON (check for burned-out bulbs).
4. Confirm that the load being controlled does not exceed the 1200W switch limit.
5. Confirm that unit is programmed properly. Repeat program procedure from Step 6 under "TO INSTALL" section.

NOTE: If the module still does not operate properly after following steps 1-5, the fault may not lie with the module. Proceed with steps 6 and 7.

6. Set the controller to transmit address P1. Using a Cat No. 6386 Signal Strength Indicator plugged in on the same branch circuit as the controller, confirm that the controller is transmitting a minimum reading of 2 volts of command signal at the HI-RANGE setting. If the signal strength is less than 2 volts, have the controller checked.
7. Check for adequate command signal at the Cat. No. HCS10 location as follows:
 - A. Plug the Cat. No. 6385 Signal Test Transmitter into a receptacle on the same circuit as the controller.
 - B. Using the Cat. No. 6386 Signal Strength Indicator at the HCS10 location, check the command signal amplitude. Signal strength must be 100mV minimum. If there is less than 100mV of signal present, it may be necessary to couple both legs of the 120/240 volt power service at the entrance panel using Cat. No. 6299 Signal Bridge.
 - C. If the Yellow ERROR CONDITION indicator is lit, there is electrical "noise" present on the AC line which is interfering with proper module operation. The source of the noise must be identified and either filtered out or eliminated (**See Technical Manual**).

Wiring Diagram 1 – Single Pole Application Incandescent / Fluorescent / Magnetic Low-Voltage

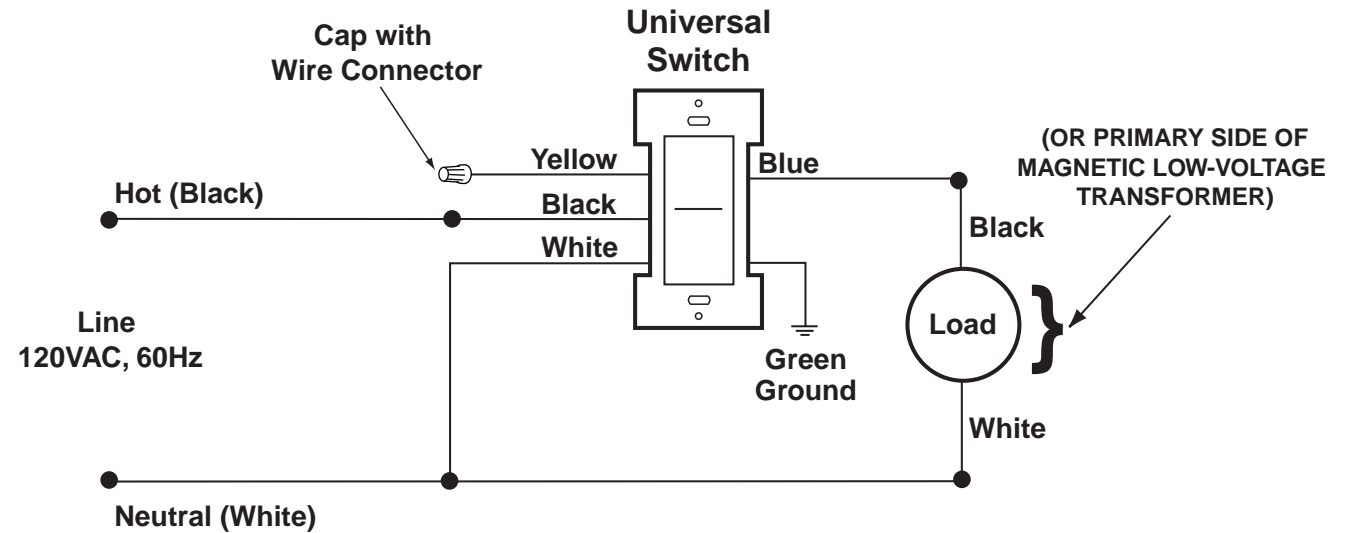

Wiring Diagram 2 – 3-Way Application Incandescent / Fluorescent / Magnetic Low-Voltage

