



Cat. No. HCC1D



WALL MOUNTED CONTROLLER

w/ Single Addressing

Cat. Nos.

HCC1Ø

HCC1A

HCC1D

120VAC, 60 Hz

INSTALLATION INSTRUCTIONS



PK-93027-10-00-0B

LIMITED TWO YEAR WARRANTY AND EXCLUSIONS

Leviton warrants to the original consumer purchaser and not for the benefit of anyone else that this product at the time of its sale by Leviton is free of defects in materials and workmanship under normal and proper use for two years from the purchase date. Leviton's only obligation is to correct such defects by repair or replacement, at its option, if within such two year period the product is returned prepaid, with proof of purchase date, and a description of the problem to **Leviton Manufacturing Co., Inc., Att: Quality Assurance Department, 59-25 Little Neck Parkway, Little Neck, New York 11362-2591**. This warranty excludes and there is disclaimed liability for labor for removal of this product or reinstallation. This warranty is void if this product is installed improperly or in an improper environment, overloaded, misused, opened, abused, or altered in any manner, or is not used under normal operating conditions or not in accordance with any labels or instructions. There are no other or implied warranties of any kind, including merchantability and fitness of a particular purpose, but if any implied warranty is required by the applicable jurisdiction, the duration of any such implied warranty, including merchantability and fitness for a particular purpose, is limited to two years. Leviton is not liable for incidental, indirect, special, or consequential damages, including without limitation, damage to, or loss of use of, any equipment, lost sales or profits or delay or failure to perform this warranty obligation. The remedies provided herein are the exclusive remedies under this warranty, whether based on contract, tort or otherwise.

For Technical Assistance Call:
1-800-824-3005
www.leviton.com

FEATURES

- Leviton's Decora® Style design
- Memory retained after Power Interruption
- Universal design works with 1 and 2-Way Receivers
- Color conversion available

INTRODUCTION

Leviton Residential Powerline Carrier Components are designed to provide the greatest signal integrity and noise immunity possible. However, in some environments intense electrical noise can cause interference with the signal. Leviton has developed hardware and techniques for overcoming this interference when properly applied.

LEVITON'S DHC DEVICES FEATURE INTELLISENSE, THE RIGHT TYPE OF AUTOMATIC GAIN CONTROL (AGC)

Leviton DHC devices use Intellisense, a special gated-type of AGC, to help eliminate noise problems (refer Figure 1). This circuit feature is ideal for powerline carrier systems because it only operates during the signal window when receivers listen for command signals. Noise levels in the signal window are never as high as they are during other portions of the AC power curve. Therefore, Leviton's Intellisense gated AGC will desensitize a receiver to noise signals with only a minimal reduction in command signal sensitivity. The result: Problems from noise interference are dramatically reduced without affecting overall system performance.

It is the responsibility of the specifier/installer to test for signal strength and the presence of noise using Leviton test equipment, Cat. Nos. 6385 (Signal Test Transmitter) and 6386 (Signal Strength Indicator), and to properly apply signal coupling and noise reduction equipment according to the guidelines provided in the Decora® Home Controls (DHC) Technical Manual and the DHC Troubleshooting Guide.

Leviton specifically denies any warranty of performance, stated or implied, where electrical noise interference exists at the time of installation, or subsequent to installation by the addition of noise-producing devices or equipment, or where these components have been installed for non-residential applications. Installation of a Repeater/Coupler is recommended in all DHC systems.

DHC Components are for residential use only. Installation for any other application voids any warranty, stated or implied.

DESCRIPTION

Wall box Transmitter

The HCCxx is a signal transmitter that works in conjunction with DHC receivers. The Wall-Mounted DHC Transmitter is designed to provide manual control of loads from one or more locations in a home over standard 60Hz 120V wiring.

The HCCxx Transmitter Body incorporates Leviton's exclusive Intellisense™ Automatic Gain Control (AGC) circuitry to deliver clearer and stronger line signals without affecting signals simultaneously on the line from other transmitters. The resulting performance reliability exceeds that of any other powerline carrier home automation product line available today.

FCC COMPLIANCE STATEMENT

This equipment has been tested and found to comply with the limits for a Class B digital device, pursuant to Part 15 of the FCC rules. These limits are designed to provide reasonable protection against harmful interference in a residential installation. This equipment generates, uses, and can radiate radio frequency energy and, if not installed and used in accordance with the instructions, may cause harmful interference to radio communications. However, there is no guarantee that interference will not occur in a particular installation. If this equipment does cause harmful interference to radio or television reception, which can be determined by turning the equipment OFF and ON, the user is encouraged to try to correct the interference by one or more of the following measures:

- Reorient or relocate the receiving antenna.
- Increase the separation between the equipment and the receiver.
- Connect the equipment into an outlet on a circuit different from that to which the receiver is connected.
- Consult the dealer or an experienced radio/tv Technician for help.

SPECIFICATIONS

Rating: 120VAC, 60Hz
 Max. Controllers on 1 circuit: 4
 Power Consumption: 3W

HCCxx CONFIGURATIONS

HCC1Ø: 1 address, ON/OFF, (1 rocker)
 HCC1A: 1 address, ALL ON/ ALL OFF, (1 rocker) - All in House Code
 HCC1D: 1 address, ON/OFF, (1 rocker), DIM/BRIGHTEN (inner rocker)

NOTE: Cat. No. HCCxx Wall Mounted Controller is not intended to replace standard wall switches. The Controller requires one HOT (BLACK), one NEUTRAL (WHITE) conductor and proper grounding for proper operation. Incorrect installation will void warranty.

INSTALLATION INSTRUCTIONS

WARNING: TO BE INSTALLED AND/OR USED IN ACCORDANCE WITH APPROPRIATE ELECTRICAL CODES AND REGULATIONS.

WARNING: IF YOU ARE NOT SURE ABOUT ANY PART OF THESE INSTRUCTIONS, CONSULT A QUALIFIED ELECTRICIAN.

WARNING: INSTALL TO CONTROL SCENE DIMMERS AND APPLICABLE DHC RECEIVERS ONLY. **DO NOT** INSTALL TO CONTROL ANY LOAD DIRECTLY.

CAUTION: USE THIS DEVICE ONLY WITH COPPER OR COPPER CLAD WIRE. WITH ALUMINUM WIRE USE ONLY DEVICES MARKED CO/ALR OR CU/AL.

TO INSTALL:

- WARNING:** TO AVOID FIRE, SHOCK, OR DEATH; TURN OFF POWER AT CIRCUIT BREAKER OR FUSE AND TEST THAT POWER IS OFF BEFORE WIRING!
- Remove approximately 3/4" (1.9 cm) of insulation from circuit conductors.

Figure 1 - Intellisense AGC

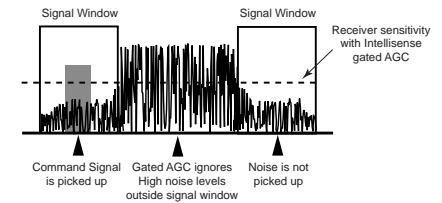
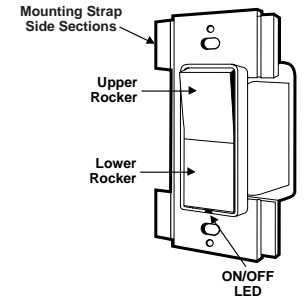

Figure 2 - Control Functions

(Cat. No. HCC1Ø and HCC1A)



(Cat. No. HCC1D)

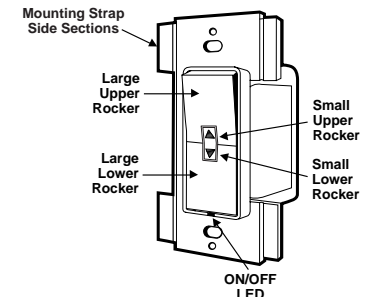
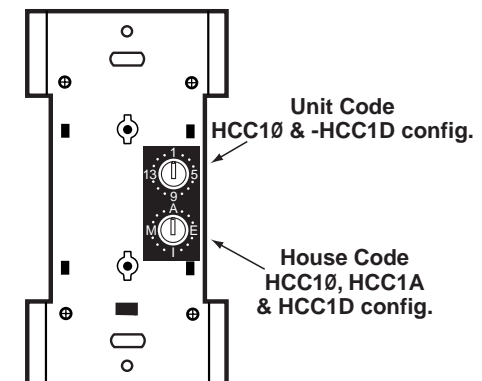

Figure 3 - Indicator Position Diagram



3. Connect wires per appropriate WIRING DIAGRAM as follows: BLACK (Hot) wire to BLACK lead of device, and WHITE (Neutral) to White lead of device. Twist strands of each lead tightly together and, with circuit conductor, push firmly into appropriate wire connector. Screw connector on clockwise making sure that no bare wire shows below the connector. Secure each wire connector with electrical tape.
4. Remove Front Face of Cat. No. HCCxx (refer to Color Conversion Procedure) to access Control Wheels.
5. Using a small screwdriver (included), set the Number Code and Letter Code dials to the desired address by gently turning the indicators to the proper positions (refer to Figure 3 and the examples in the Testing section).
NOTE: The HCC1A is only equipped with a housecode dial (refer to Figure 3).
6. Mount Cat. No. HCCxx in wall box using the screws provided.
NOTE: If mounted in a multi-gang box, one or more of the side sections may have to be removed. Use pliers to carefully bend side sections back and forth until they break off (refer to Figure 2).
7. Replace Front Face (refer Color Conversion Procedure).
8. Mount wallplate.
9. Restore power at circuit breaker or fuse. **INSTALLATION IS COMPLETE.**

COLOR CONVERSION PROCEDURE

The color of this device can be changed to suit your interior design requirements. Simply obtain a color conversion kit of the appropriate color from your Leviton distributor and proceed as follows (please note that the wallplate must be removed).

1. Select the color of the face you desire.
2. The frame has snaps on its sides. Using a small screwdriver, **gently** remove the frame from the strap (refer Figure 4).
3. Take the new frame and position it properly to the strap. Line up the plastic snaps with the square holes in the strap. Insert the snaps on one side of the frame into the strap.
4. Firmly press sideways and down to slip the other snaps into place. The frame snaps in with an audible click. Ensure that all four snaps are secure. Replace Decora® wallplate. **The color conversion is complete.**

TO OPERATE (Cat. Nos. HCC1Ø, HCC1A and HCC1D)

Pressing the upper half of the large rocker will transmit ON and ALL ON commands (Cat Nos. HCC1Ø, HCC1A and HCC1D). Pressing the bottom half of the large rocker will transmit OFF and ALL OFF commands (Cat Nos. HCC1Ø, HCC1A and HCC1D). Pressing the upper half of the small rocker will transmit the BRIGHT command (Cat No. HCC1D). Pressing the bottom half of the small rocker will transmit the DIM command (Cat No. HCC1D).

When transmitting an ON/ALL ON command, the LED will blink while the signal is being transmitted and will stay ON when the signal has completed the transmission. When transmitting an OFF/ALL OFF command, the LED will blink while the signal is being transmitted and turn OFF when the signal has completed the transmission. If there is a BRIGHT/DIM function on the keypad, pressing the BRIGHT or DIM button will cause the LED on the face of the keypad to flash and will remain flashing until the button is released.

NOTE: When used with a 2-Way Receivers, the LED's will indicate the status of those devices (i.e., if the Dimmer is turned ON at it's source, the ON/OFF LED on the Transmitter will turn ON).

TESTING

Press the keypad to confirm that the load or loads are turned ON and OFF within two seconds of signal transmission. If the Cat. No. HCCxx Controller appears to be functioning improperly or operates erratically, read the following paragraphs, then refer to the Perfect Performance Checklist.

An ALL ON/OFF (Cat. No. HCC1A) controls all DHC modules set to the same letter code as on the Cat. No. HCCxx Controller. ALL ON **ONLY** turns ON lighting modules. ALL OFF turns OFF **ALL** modules set to the same letter code.

PERFECT PERFORMANCE CHECKLIST

If the Cat. No. HCCxx Controller appears to be functioning improperly proceed with the following steps:

1. Confirm that the Controller is wired exactly as shown in the wiring diagram.
2. Confirm that the receiver module is being supplied from a 120V, 60Hz AC source **ONLY**.
3. Confirm that the load being controlled is in proper working order. Local switch, ON (check for burned-out bulbs, etc.).
4. Confirm that the Controller is powered and is set to transmit commands to the same letter and number code on receiver modules.
5. Confirm that the Cat. No. HCCxx keypad is installed properly.

NOTE: If the Controller still does not operate properly after following steps 1-5, proceed with diagnostic steps 6 and 7.

6. Set the Controller to transmit address P1. Using a Cat No. 6386 Signal Strength Indicator plugged in on the same branch circuit as the Controller, confirm that the Controller is transmitting a minimum reading of 2 volts of command signal at the HI-RANGE setting. If the signal strength is less than 2 volts, have the Controller checked.
7. Check for adequate command signal at the Cat. No. HCCxx location as follows:
 - A. Plug the Cat. No. 6385 Signal Test Transmitter into a receptacle on the same circuit as the Controller.
 - B. Using the Cat. No. 6386 Signal Strength Indicator at the HCCxx location, check the command signal amplitude. Signal strength must be 100mV minimum. If there is less than 100mV of signal present, it may be necessary to couple both legs of the 120/240 Volt power service at the entrance panel using a Leviton Repeater/Coupler.
 - C. If the Yellow ERROR CONDITION indicator is lit, there is electrical "noise" present on the AC line which is interfering with proper module operation. The source of the noise must be identified and either filtered out or eliminated (See **Technical Manual**).
8. Installation of a Coupler/Repeater is recommended in all DHC installations for maximum signal.
9. The Leviton Technical Manual covers common DHC problems and system issues in more detail.

Figure 4 - Switch Plate Removal
(Color Conversion Only)

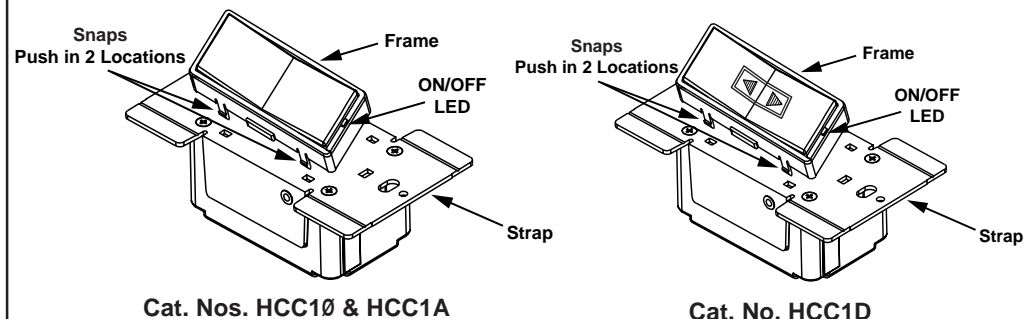

Wiring Diagram 1
Cat. Nos. HCC1Ø & HCC1A

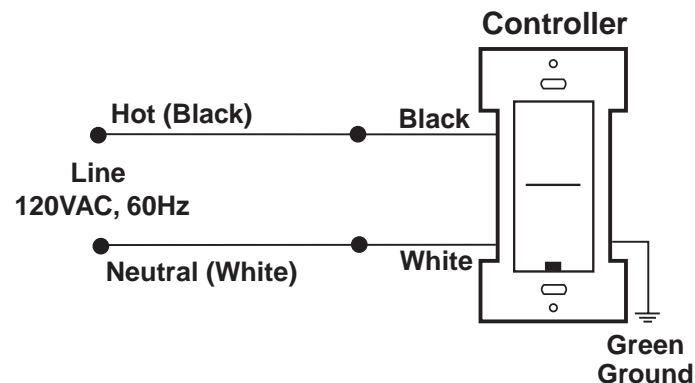

Wiring Diagram 2
Cat. No. HCC1D

