

THE CR230 is a coupler-repeater designed to receive PCC signals, **both standard and X-10 extended code**, from one phase of a 120/240 VAC split-single phase power distribution system and re-transmit them onto both phases. In doing so, it effectively amplifies the signal. The CR230 is also capable of receiving and re-transmitting **Dim and Bright signals** nearly simultaneously. The CR230 consumes 2 watts at rest, and 12 watts when transmitting. Its signal output is approximately 5 volts peak to peak @ 5 ohms. Actual output is dependent on facility impedance. This unit **IS NOT** intended for 120/208v, 120/240/208 high leg delta, or 277/480v systems.

120/240 VAC 1 Phase
Distribution System

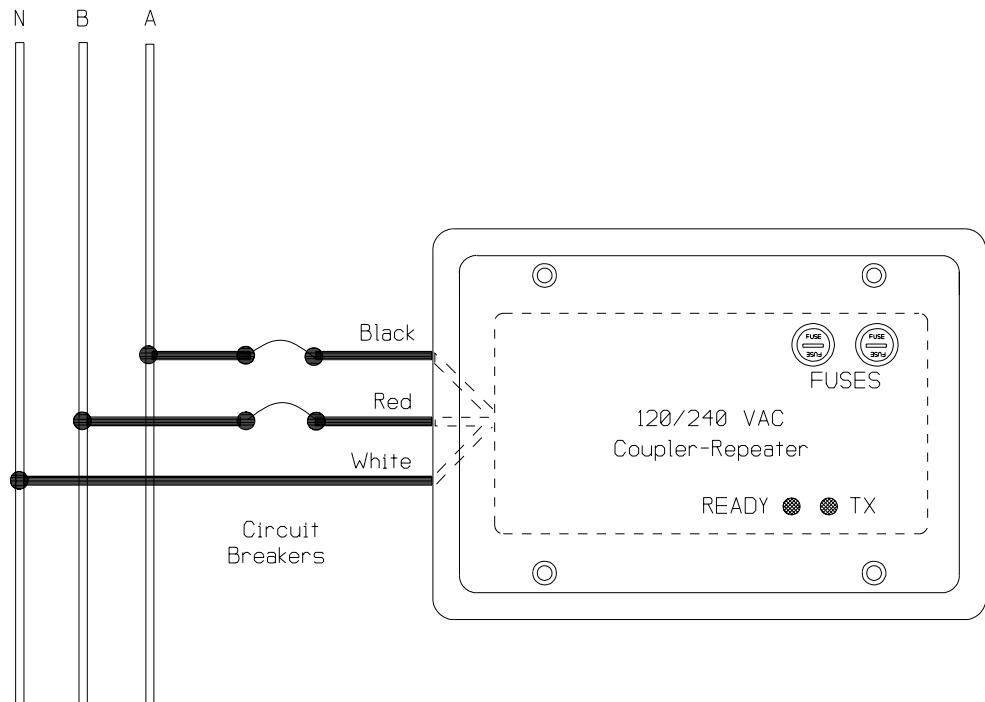

BEFORE YOU BEGIN...

READ ALL INSTRUCTIONS

Make sure your installation will conform to all applicable electrical codes and requirements.

TEST FOR SIGNAL STRENGTH AND INTERFERENCE...

using the appropriate test equipment. It is necessary to test the installation in the actual operating environment. The amount and types of line loads may reduce the signal strength and/or electrical interference may degrade the signal. To insure a fully functional system, special coupling devices may be required to allow signal to be distributed to all phases and zero-crossings in multi-phase and multi-transformer power distribution systems.

IF YOU HAVE ANY QUESTIONS...

Consult your nearest Engineered System Center (ESC) for technical assistance. There are no field repairable assemblies on this unit, except for the two (2) 3AG, 1/2 amp, 250V, Slo Blo replaceable fuses (LittleFuse # 313.500). It is covered by a two year limited warranty. Should service be required, please contact the ESC from where it was purchased.

INSTALLATION

CAUTION! Make all connections with the **POWER OFF** to avoid injury to the installer or damage to the device. Tools required are those commonly used in basic electrical work.

1. Remove the CR230 from its packaging. Do not discard packaging or instructions until the installation is complete and operational.
2. Determine the proper location for the CR230 (usually at the main breaker panel) and prepare an enclosure, if used (the CR230 will fit a triple wall box) as determined by local and national electrical codes.
3. Prepare the required breakers as determined by local and national electrical codes. Although dedicated circuit breakers make the installation easier, the CR230 may share breakers with other equipment. Additional wire is usually required (not included). Fuses incorporated in the CR230 are not a substitute for electrical circuit breaker protection.
4. If not already done, strip 3/4" of insulation from the ends of the conductors.
5. With the breakers **OFF**, make the connections as shown in the diagram on page 1, using correctly sized wire nuts.
6. Secure the CR230 into the enclosure (if used).

CHECKOUT

1. Turn the circuit breaker(s) on. The green (*Ready*) LED should light.
2. Using an AT004 test transmitter or any appropriate PCC transmitter on the electrical system, transmit a PCC signal. The red (*TX*) LED will flash.
3. When all appropriate signal strength tests are complete, replace the enclosure cover (if used).

Any questions about installation should be directed to the distributor where this unit was purchased.

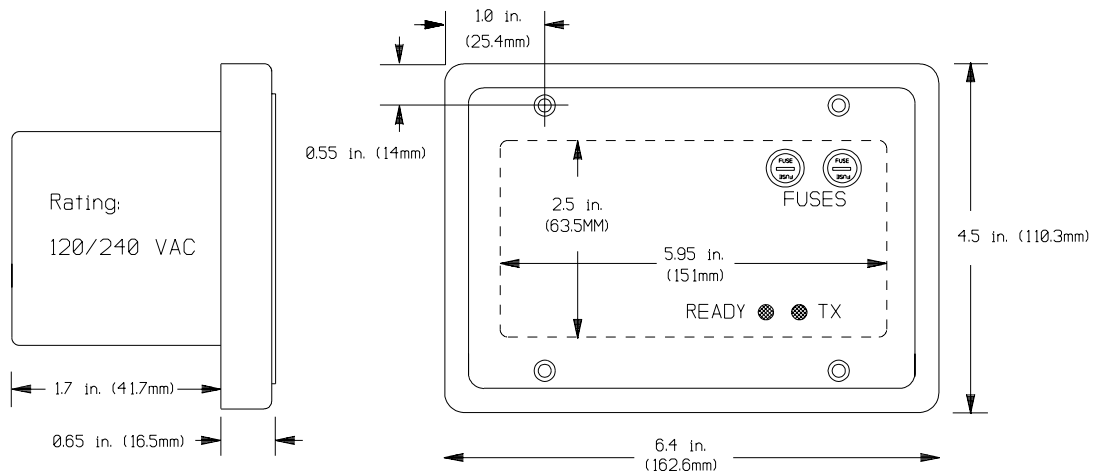

Power Consumption: 2 watts at rest, 12 watts when transmitting.

Signal output: Approximately 5 volts peak to peak @ 5 ohms.

Replaceable Fuses: Two (2) 3AG, 1/2 amp, 250V, Slo Blow (LittleFuse # 313.500)