

1. INTRODUCTION

In this package, you will find a keychain transmitter with 12V alkaline battery, a wireless switch receiver and a clip.



2. SET UP THE OPERATION CODE FOR BOTH TRANSMITTER AND RECEIVER

It is recommended to randomly set the operation code for your remote control to avoid interference from other devices. Follow the instructions below to change the operation code.

- 1 Pry off the battery cover on the transmitter with a coin, as shown. You will see 9 connectors labeled from "1" to "9", as shown.
- 2 You can randomly remove some of these connectors, leaving some connectors in place. A connector can be removed with the clip, as shown.
- 3 If the connector is placed on the top and middle posts, that column is set on "+". If the connector is placed on the middle and bottom posts, that column is set on "-". If the connector is removed completely, (not placed on any posts), it is set to "0". (see diagram for examples of how to set a column to the three different positions). When removing a connector to set a column to "0" position, save the connector in case you change the code at a later date.
- 4 After setting up the code connectors on the transmitter, you are ready to set the same code on the receiver.

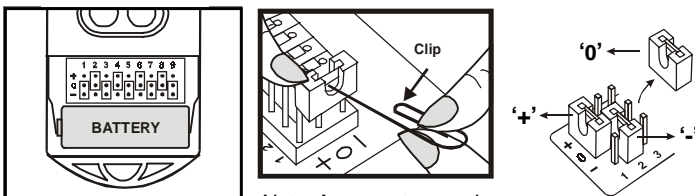
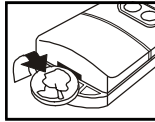

Note: A connector can be removed with the clip, as shown.

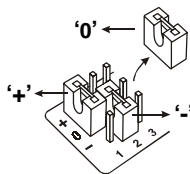

WARNING

Remove the receiver from the electrical outlet before changing the code.

- 5 Remove the screw that holds the connector cover, and pry off the cover.

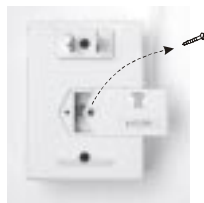

2. SET UP THE OPERATION CODE FOR BOTH TRANSMITTER AND RECEIVER (CONT)

- 6 You will see 10 connectors. For connectors "1" to "9", the settings must match with those of the transmitter.

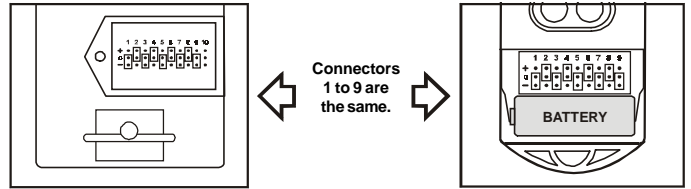

- 7 For connector "10" on the receiver, set the connector on "+" if you are using button "1" to control this receiver. If you are planning to use button "2" to control this receiver, you need to remove this connector. See diagram below.

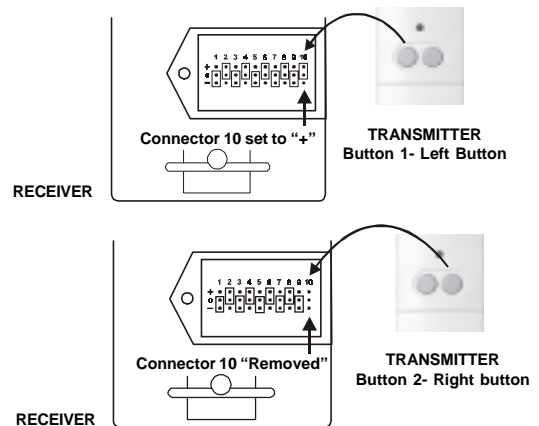

- 8 Put the cover and screw back onto the receiver. Plug the receiver into an electrical outlet.
- 9 Put the battery cover back onto the transmitter.

3. INSTALLATION

- 1 Plug the receiver into a powered, 120VAC electrical outlet inside your house. (Note: This receiver is designed to be used indoor only. Do not use this receiver in an outdoor environment.)
- 2 Once the receiver is plugged into an electrical outlet, the red LED on the front of the unit will be "on" indicating the unit is in standby mode.
- 3 Plug in the light fixture or small appliance that you would like to control into the receiver, as shown.
- 4 If there is a power switch on the plugged in light fixture or small appliance, please turn it on. The receiver is ready to be activated.
- 5 Pressing the appropriate button will turn on the plugged in device and the red LED on the front will flash. (Caution: When the red LED on the unit is flashing, that means output outlet is powered. Do not disconnect / connect devices from / to the receiver's outlet when the red LED is flashing.)



4. OPERATION

To activate the receiver, simply press the appropriate button on the transmitter, it will activate the plugged in device. Pressing it again will turn off the plugged in device.

5. BATTERY

12 volt alkaline battery (size 23A) (included).

It is time to change the battery when the red LED on the transmitter does not turn on when either button is pressed.

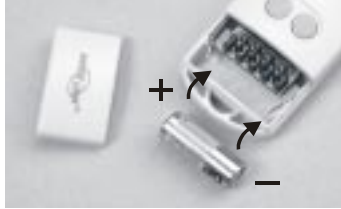

6. ADDITIONAL RECEIVER

There are 2 buttons on your transmitter, the other button can be used to control another Houselink® Garage Door Receiver Model 318R (sold separately) or Houselink® Wireless Switch Receiver Model SW-318R (sold separately).



7. ADDITIONAL TRANSMITTER

You can add as many additional transmitters as you want to control the same receiver. Simply set the same operation code on all transmitters with the same code setting on the receiver. Houselink® offers Keychain Transmitter Model 318TN to work with your receiver. For more information, please visit our website at www.skylinkhome.com or contact us.



8. CAUTION

RISK OF ELECTRICAL SHOCK. FOR INDOOR USE ONLY.
CAUTION : NOT FOR USE WITH DIMMER.

DISCONNECT POWER BEFORE CODE SETTING.
REPLACE COVER AFTER CODE CHANGING.

Maximum Rating :
Input : 120VAC 60Hz
Resistive load : 8A (960W)
Incandescent : 300 watts
Motor Load : 1/3 HP

9. FCC

This device complies with Part 15 of the FCC Rules. Operation is subject to the following two conditions:
(1) This device may not cause harmful interference, and (2) This device must accept any interference received, including interference that may cause undesired operation.

WARNING:
Changes or modifications to this unit not expressly approved by the party responsible for compliance could void the user's authority to operate the equipment.

NOTE:
This equipment has been tested and found to comply with the limits for a Class B digital device, pursuant to Part 15 of the FCC Rules. These limits are designed to provide reasonable protection against harmful interference in a residential installation. This equipment generates, uses and can radiate radio frequency energy and, if not installed and used in accordance with the instructions, may cause harmful interference to radio communications.

However, there is no guarantee that interference will not occur in a particular installation. If this equipment does cause harmful interference to radio or television reception, which can be determined by turning the equipment off and on, the user is encouraged to try to correct the interference by one or more of the following measures:

- Reorient or relocate the receiving antenna.
- Increase the separation between the equipment and receiver.
- Connect the equipment into an outlet on a circuit different from that to which the receiver is connected.
- Consult the dealer or an experienced radio/TV technician for help.

10. WARRANTY

If, within one year from date of purchase, this product should become defective (except battery), due to faulty workmanship or materials, it will be repaired or replaced, without charge. Proof of purchase and a Return Authorization are required.

11. CUSTOMER SERVICE

If you would like to order Skylink's products or have difficulty getting them to work, please :

1. visit our FAQ website at www.skylinkhome.com, or
2. email us at support@skylinkhome.com (reply within 24 hrs), or
3. call our toll free at 1-800-304-1187 from Monday to Friday, 9 am to 5 pm EST.
Fax +800 286-1320

CUSTOMER SERVICE

Email:support@skylinkhome.com (Reply within 24 hrs)

<http://www.skylinkhome.com>

P/N. 101A208-001 Rev.1

US Patent. D380895

©2003 SKYLINK GROUP